

OWNER'S GUIDE

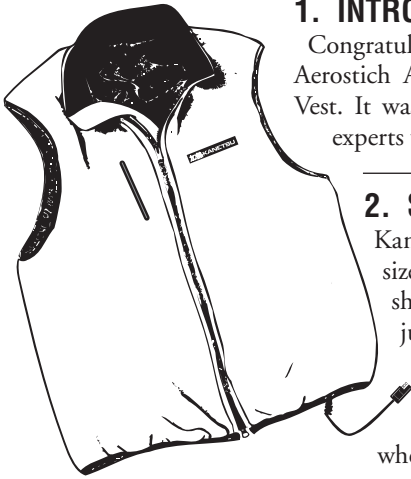

1. INTRODUCTION

Congratulations on your choice of an Aerostich Airvantage Kanetsu Electric Vest. It was hand made by a team of experts who are proud of its quality.

To receive the best performance from your Kanetsu vest please read this owner's guide. We hope that you will enjoy your new vest for many years and thousands of miles. If you have any questions, comments, or suggestions please call us at (218) 722-1927. Thank you for choosing an Kanetsu Airvantage Electric Vest.

2. SIZING & FITTING

Kanetsu vests are offered in sizes Small through XXL. You should choose a size that is just large enough to wear over a T-shirt, sweatshirt, or riding shirt. Electric clothing is most effective when worn close to your body,

but the fit should not restrict your freedom of movement or interfere with comfort. When the vest is zipped up, move through a full range of motion to insure your fit is correct. A close (but comfortable) fit is recommended. The size Small is a men's 34-36" chest measure. Medium is a men's 38-40". Large is a 42-44". Extra Large is a 46-48". XXL is a 50-52". If you normally wear a size 40, you would probably fit best in a size Medium. All sizes are cut to provide freedom of movement and to be worn underneath additional layering in colder conditions. Custom sizing alterations are not available.

3. ELECTRICAL SETUP AND OPERATION

First, permanently attach the red power lead to the positive (+) terminal of your battery and the black power lead to the negative (-) terminal. Position the wires and in-line fuse holder so they cannot be abraded or pinched. Route the waterproof connector to a convenient access position on the left side of your motorcycle and secure it in place with the enclosed zip tie.

To operate your vest, remove the power cord from its storage pocket, connect the cord to the vest, and zip the cord storage pocket closed leaving the cord hanging down on your left side. The coiled power cord routes out the left side of your riding clothing to the connector on your bike. If you are using an Aerostich one piece Roadcrafter suit, the power

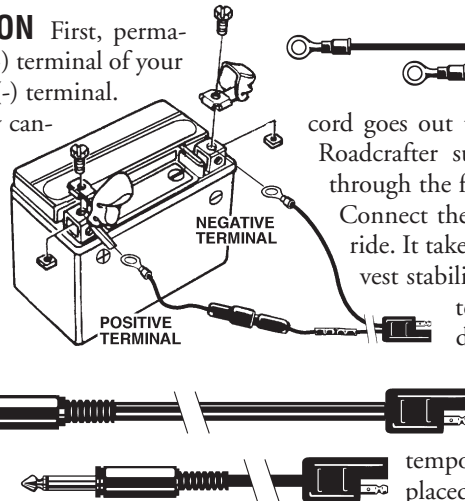

cord goes out the suit's side entry access zipper. Two piece Roadcrafter suits are similar but the cord may also go through the front, between the jacket and pants.

Connect the vest to your motorcycle and you're ready to ride. It takes two or three minutes to feel warmth and the vest stabilizes at its maximum temperature in about fifteen minutes. Make sure that the power cord does not touch superheated engine/exhaust parts, will not be caught in any moving parts and cannot interfere with your control of the motorcycle. When the power cord is temporarily disconnected, the loose plug end can be placed in one of your jacket's pockets.

4. COOL WEATHER USE (20°-55°F) For maximum heat transfer, wear the vest as a second layer, fleece side out, directly over your shirt or other light garment. You should add an insulating layer (like a sweater or fleece garment) over the vest to retain as much heat

as possible. If your riding jacket is not large enough to allow wearing thicker insulating layers, try a second riding shirt or sweatshirt. Adding even a lighter garment between the vest and your jacket (or riding suit) makes a noticeable difference.

5. WARM WEATHER USE (55°+) In warmer weather you may wish to experiment with a variety of clothing combinations. Your Kanetsu vest is reversible and performs differently when worn each way. Worn with the black nylon side towards you it's heating wires are positioned closer for greater warmth,... but with the fleece

side in, the heat is moderated by the thickness of the fleece. In warmer conditions the collar can be folded down for increased comfort. If you wear an Aerostich Darien jacket the Kanetsu vest may be zipped directly in place of the standard Darien liner.

6. PACKING Disconnect the power cord and zip it into its storage pocket. The vest may be stored in the large zippered pocket (located on the back) by turning it 'inside out' and stuffing it into

this pocket. Because fleece is such springy stuff you may have to practice a couple of times before being able to do it neatly and quickly. You cannot break or damage the electric wires stuff-packing the vest.

7. ELECTRIC VEST PRINCIPLES When you get cold, your body automatically decreases the amount of blood circulating to your limbs and skin to decrease the rate of heat loss and protect your head and vital organs for the longest possible time. When you're riding through a damp 55° evening and your hands and feet feel

frozen, it's because your body is trying to protect you by shutting off some of the blood to your extremities. An electric vest keeps your trunk warm. Your body senses this and allows more blood to circulate to your fingers and toes, letting you ride in greater comfort and control.

8. LAUNDRY AND CARE Do not dry clean. Hand washing is recommended. Remove contents of all pockets. Close all pockets and zippers. Wash using only a mild detergent. Hang dry only.

Silicone spray on the zipper teeth will help the slider move easier, and Scotchgard® or a similar spray will help water to “bead” on the liners’ surface fibers in rainy conditions.

9. EXCHANGES AND REPAIRS Please send all items insured and prepaid. Include your name, address, daytime phone number and reason for the return. Exchanges and returns for refund must be in new condition. Returns for repair must be clean. If your vest requires additional cleaning before being repaired, you will be charged. If major repairs are needed, we will contact you with a

quote before beginning work. If repair costs exceed half the vest’s replacement value the vest is “totalled”, and will not be repaired. Some sewing shops in your area may also be able to repair or alter your vest. If needed, call us, and we will send any materials required (such as fabrics, wires, zippers, etc.).

10. FEATURES & SPECIFICATIONS

- Reversible design.
- Heated two position Ultrasuede collar.
- Lightweight GORE-TEX® WINDSTOPPER® outer fabric with Supernyl lining fabric.
- Durable Lycra edge binding.
- Self storage zipper pocket.
- Cord storage pocket.

- Detachable coil cord with integrated on/off switch.
- Easy to connect jack and plug.
- Elastic waist gathers for a close fit.
- Fused power cord.
- Machine washable.

Power requirements: 45 watts at 13.6 volts. 3.3 amps.
4.12 Ohms resistance. Inline fuse type AGC 1¼" Size 10 AMP.

11. USE SUGGESTIONS Your Kanetsu vest is lighter, more comfortable to wear, smaller to pack and easier to use than some types of heated clothing. Its GORE-TEX® WINDSTOPPER® provides less direct insulation than quilted types of interlinings, but is more comfortable to wear in a broader range of conditions. Your vest is a convenient, dependable source of supplemental heat that is ideal for commuting and three season trips.

The standard coiled power cord and QuickConnect adapter are light, small to pack and easy to handle,... but have slightly more electrical resistance than bulkier cords. Heated vests all stabilize at 105–110 degrees. It takes between ten and fifteen minutes to reach this warmth. With the standard coil cord, your Kanetsu vest takes a bit longer (1–2 min.) to reach maximum warmth than it would with a larger gauge cord or with the optional Heat-Troller thermostat. For the quickest warmup time use a Heat Troller thermostat or an 18 gauge connector wire.

The standard molded SAE type connectors ease-of-use can be

improved by repeatedly plugging, unplugging, flexing and twisting them (one pin at a time) until they ‘break-in’. Doing this 50–100 times will make a big difference. The QuickConnect jack is not waterproof and has slightly more electrical resistance than the SAE connectors. In extremely wet conditions you should position the jack’s opening downward. The optional Heat-Troller thermostat and its included wiring are as low in resistance as a direct wire, (so the vest heats faster) but with the added comfort of regulated temperature.

Some riders custom make a simpler coil cord: A QuickConnect jack is soldered directly at the cord’s end (no SAE connectors), without a power switch. The other side of the QuickConnect jack is soldered to a wire routed from the battery to a convenient location (usually near the tank bag or handlebars) where the QuickConnect jack can be plugged or unplugged with one hand. This setup is reliable, compact to pack and easy to use.

LIMITED GUARANTEE To the original purchaser, Aero Design & Manufacturing Company, Inc., the manufacturer and seller of Aerostich RiderWear products, guarantees all Aerostich RiderWearHouse products against defects in materials and workmanship for two full years. Since no Aerostich product is indestructible, this guarantee does not cover: ordinary wear, soiling, aging, misuse or accidents. Repairs due to normal wear and tear over time or accidents



will be done at a reasonable charge.

MONEY-BACK SATISFACTION: If you are dissatisfied with any RiderWearHouse Catalog product in any way, you have 30 days from the date of delivery to return the item in an undamaged and unsoiled condition for a full refund, by pre-paid delivery to: Aero Design and Manufacturing Company, Inc., 8 South 18th Ave West, Duluth, Minnesota, 55806. Crafted With Pride in the U.S.A.

ABOUT THE NAME KANETSU Kanetsu is a Japanese word that combines two Kanji language characters/symbols. ‘Ka’ means ‘adding or increasing’ and ‘Netsu’ means ‘heat or temperature’. Kanetsu = Adding heat. In 1995, the Aerostich electric vest was introduced in a RiderWearHouse Catalog several months before we were actually able to produce them. (They were un-obtainable.) The name ‘Unobtainium’ fit the circumstances so it was registered as the vest’s trademark in the category of clothing. Several years later the Oakley company, which owned an ‘Unobtainium’ trademark in

another category (rubber for eyeglass ear stems and motorcycle hand grips), said that this use was damaging to them. Although we had a good legal position, the cost to defend our ‘Unobtainium’ trademark would have been several hundred thousand dollars...so we settled the lawsuit and give this trademark to Oakley. We could not support a full defense and the Kanetsu electric vest (and Darien liner) had become entirely and immediately obtainable, anyway. Kanetsu electric liners and vests are now sold worldwide...including in Japan.

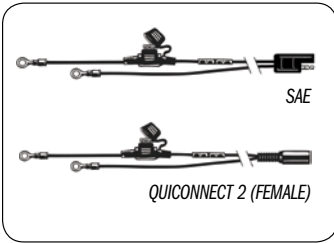

Battery Fuse Cords

Use a Kanetsu Vest or Electric Darien Liner with a second motorcycle. Standard equipment supplied with all new Kanetsu Vests or Electric Darien Liners. 10 A Fuse. Length 25".

SAE #112 \$10.00
QuiConnect 2 #176 \$10.00

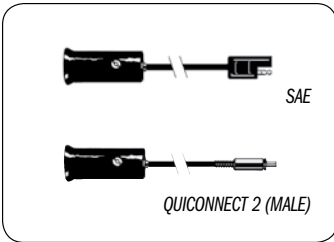

Power Sockets

A short connector wire with a plug that fits a cigarette lighter/accessory socket. The other end fits your Kanetsu Vest Switch or Electric Darien Liner cords. Specify SAE or QuiConnect 2. Length 7".

SAE #168 \$10.00
QuiConnect 2 #169 \$10.00

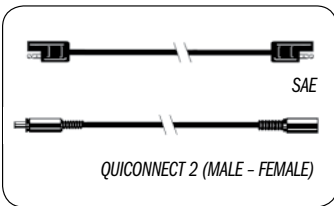

Powercord Extensions

A straight cord that allows the attachment point to be relocated to a higher and/or more forward point for easier use. Length 30".

(A) SAE #109 \$8.00
(B) QuiConnect 2 #179 \$8.00

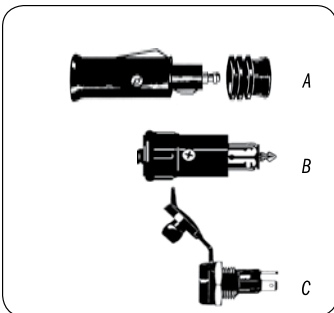

BMW Plugs & Sockets

The Dual Plug (A) is a standard male cigarette power plug that is also compatible with standard BMW power sockets upon removal of the end bushing. The BMW Plug (B) is a standard BMW power plug. The BMW Socket (C) installs to connect BMW power plugs to your bike.

(A) Dual Plug #185 \$10.00
(B) BMW Plug #181 \$8.00
(C) BMW Socket #108 \$12.00

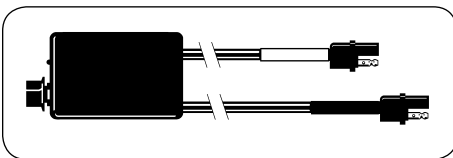

Thermostat

This thermostat works by digitally regulating the amount of power to the garment. It draws less than the full 45

watts at intermediate settings. (Resistance type thermostats draw full power at all settings.) The Aerostich Heat-Troller features a rotary on/off switch and an LED that blinks faster as you turn up the heat. (At the maximum setting the light is on continuously.) The case size is 1.5"x2.25"x.75". The Aerostich Heat-Troller is available with SAE connectors. Panel mount model includes everything needed for permanent installation. Both cords are 16" long.

SAE Thermostat #110 \$70.00
Thermostat Panel Mount #189 \$80.00

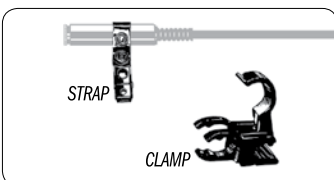

Cable Clips

Route wiring to the best places. Strap has a spring clip end and a cord-holding snap end. Clamp grabs it all.

Strap #180 \$2.00
Clamp #182 \$2.00

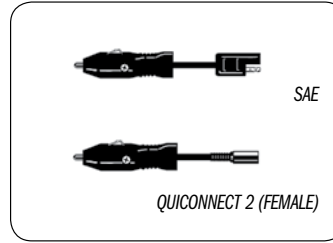

Power Plugs

Connect your Kanetsu Vest or Electric Darien Liner to a cigarette lighter/accessory socket to wear these heated garments in automobiles, construction equipment, on snowmobiles, etc. Cord length is only 1".

SAE #117 \$10.00
QuiConnect 2 #167 \$10.00
BMW #116 \$16.00

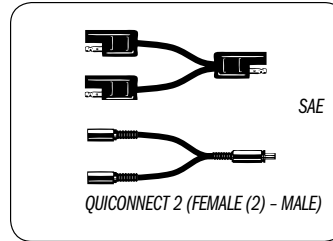

Double Adapters

Allows two vests to be connected to a single power plug. Or, for near-volcanic heat in the most wretched of conditions, use the Electric Vest and the Electric Darien Liner together. Cord length is 2".

SAE #111 \$12.00
QuiConnect 2 #191 \$12.00

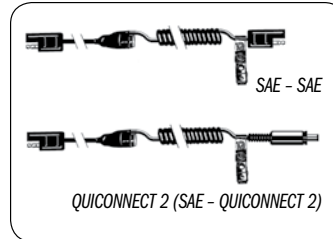

Switch Coil Cords

Standard equipment supplied with all Kanetsu Vests and Electric Darien Liners. Flexible in cool temps. Features an illuminated push button on/off switch. Stretches from 3' to 6'.

SAE #113 \$37.00
QuiConnect 2 #173 \$37.00
BMW #107 \$47.00

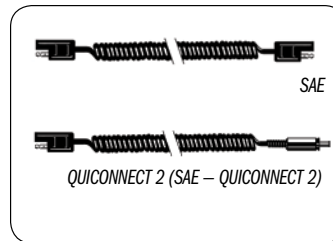

Coil Cords

A coil cord for connecting the vest to the motorcycle. The ultimate in simplicity and reliability. Remains flexible in all temperatures. Stretches from 1.5' to 5'.

SAE #114 \$15.00
QuiConnect 2 #174 \$15.00



QuiConnect 2 Jumper Cord

This connector is used as a suit side entry pocket pass-through, by eliminating the need to thread the power wire through the side entry zip in one piece suits each time you use an electric vest. The SAE end plugs into the electric garment, ending in a QuiConnect 2 coaxial male connector (inside the suit). Captured by the side entry zip, this connects to a 6.5" QuiConnect female wire with an SAE end to connect to the standard switch coil cord (outside the suit).

#162 \$17.00

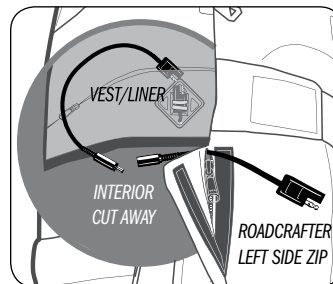

QUICONNECT 2 JUMPERCORD: THE SHORT CORD SECTION IS "CAPTURED" BY LEFT SIDE OF ROADCRAFTER POCKET ACCESS ZIP FOR FAST SUIT ON/OFF OVER ELECTRIC GEAR.

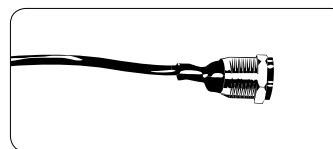

QuiConnect 2 Panel Mount

Permanently mount a female QuiConnect 2 to your bike. Fits a 7/16" wide hole in a 1/4" thick surface. 1/2" deep. Cord length: 21".

#166 \$10.00

CONNECTOR KIT COMPARISON

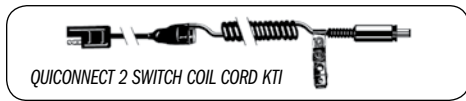

QUICONNECT 2 SWITCH COIL CORD KIT

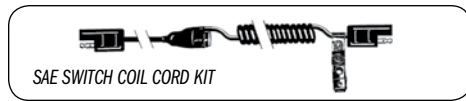

SAE SWITCH COIL CORD KIT

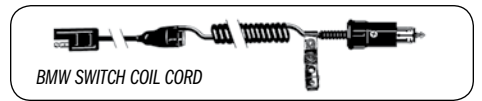

BMW SWITCH COIL CORD

Kanetsu Electric Vests and Liners come standard with either the 'QuiConnect 2 Switch Coil Cord Kit', the 'SAE Switch Coil Cord Kit', or the 'BMW Switch Coil Cord'.

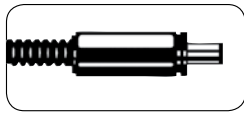

QuiConnect 2 Switch Coil Cord Kit

A coil cord with illuminated two position switch and QuiConnect 2 coaxial plug. SAE plug on the other end goes into Kanetsu Vest or Electric Darien Liner. Very easy to use. Switch has an 'up' and 'down' position and an illuminated button to indicate its function. Stretches from 3' to 6'. Cord remains flexible at low temps. Includes Battery Fuse Cord #176, Powercord Extension #179, and Switch Coil Cord #173.

#172 \$47.00

QuiConnect 2 Kit Features

- Easier to connect/disconnect with gloves and for frequent on/off stops for gas, etc...
- Not waterproof by design but there have been no failures (none) after use by 1000's of riders over 15 years. (Several brands of electric clothing).
- May be connected/disconnected one-handed.
- Will disconnect without damage if pulled by cord (as occurs when walking away from bike without first disconnecting).

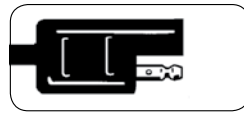

SAE Switch Coil Cord Kit

A coil cord for connecting the vest to the plug on the motorcycle. Remains flexible at low temperatures. Push button on/off switch.

Switch has an 'up' and 'down' position and an illuminated button to indicate its function. Stretches from 3' to 6'. Includes Battery Fuse Cord #112, Powercord Extension #109, and Switch Coil Cord #113.

#188 \$47.00

SAE Kit Features

- Very reliable - molded into a single piece with power cord.
- Waterproof and rugged-unaffected by rain, mist, dirt.
- Connecting and disconnecting takes two hands and requires careful alignment. Needs to be worked on and off a few times to 'break-in'.

BMW Switch Coil Cord

A connector wire that fits the standard BMW accessory socket. The separately available matching socket is extremely robust and weather resistant, fits in a 5/8" panel hole and plugs and unplugs very nicely. Cord features an illuminated two-position button. Stretches from 3' to 6'. *Socket requires additional wiring (not included) to connect to motorcycle battery.*

Cord #107 \$47.00

Accessory Socket #108 \$12.00

ELECTRICAL ITEMS



Not Quite Card Sized Multimeter

Trouble-shoot electrical problems with this slim-line design digital multimeter. Small yet rugged enough to carry on motorcycle trips. Only slightly larger than a credit card, the Wavetek DM78 features full autoranging, DC volts, AC volts, ohms, continuity, and diode test functions. Comes complete with batteries, instructions, test leads, and carrying case.

Delivers all the functions of a full size multimeter in an easier to carry (and use) size. 4.25"x2.25"x.875".

#2510 \$57.00



Fused SAE Jack

A CNC machined aluminum and stainless steel holder containing a blade fuse and an SAE outlet that can be mounted anywhere on a bike. Makes using battery chargers, electric clothing and other accessories a lot neater and easier. Includes an assortment of fuse sizes, a great installation guide and everything else needed for a ready-to-go mounting. This is the cleanest

way to jack in, and is made by a dedicated rider who wanted a neater setup than loose dangling power cords.

#2548 \$64.00



LED Battery Gauge

A precise, continuous way to monitor your bike's alternator output and battery condition. An essential instrument if your bike has bigger or extra lights, or other powered accessories. Its solid state, waterproof, ultra compact design is extremely durable. Small so it fits anywhere. Indicates from 9V to 16V using eight colored LED's. A sensor auto-dims the LED's at night. If the voltage readout goes below 10V, a red LED alert flashes. Small electrical system changes are noticeable at a glance. Two wire installation. 2"x.75"x.2"

#2577 \$39.00



Auxiliary Power Fused Panels

Supply convenient, safe fused power for up to eight individual electronic devices, such as radios, MP3 players, GPS's and other accessories. The Centech AP1 handles up to 60 amps and allows for eight connected outputs that remain on when your bike is running, off when it's not. The Centech AP2 version allows for five 'on when running/off when not' outputs and three "always on" outputs that remain active after your bike is turned off. This is especially helpful for devices that need to remain "live" such as radio memories and some GPS units. Made using plated contacts and stainless steel hardware, with a built-in grounding system, these units are rugged and water resistant multiple accessory wiring solutions. Their compact size (3"x2.4"x1") allows for easy installation inside fairings, under saddles and in other tight spots. Lugless terminals mean you simply strip wire ends, insert, and tighten set screws. Includes fuses, all mounting hardware and complete instructions. Neat, easy and safe.

AP-1 #2549 \$57.00

AP-2 #2538 \$57.00

AP-2 Wiring Harness (required for split-use function) #2539 \$36.00



Battery Tender Plus®

An improved version of the famous Battery Tender®. Lucky for you (and your battery) the cost is the same. The enhancements to the original design are in the circuitry that ensures better absorption and a built-in 72 hour safety timer will protect a marginal battery from being overcharged. The display improvements tell the user that AC power is on, when it is charging, that the battery is 80% charged, that full charge has been attained, and the unit is in 'float' charge mode. A good, useful product that just got better. Electrifying.

#2504 \$64.00

Gel Battery Charger (not shown) #4908 \$64.00

BMW Adapter Plug #116 \$16.00

AirVantage™ Vest/Liner

Owner's Guide Supplement

Congratulations on your new Aerostich Kanetsu AirVantage™ Electric Vest. For maximum performance, please follow these procedures:

1. Fit - This vest's fit is adjustable with an air filled insert. Inflating the insert will minimize drafts, add insulation, and greatly improve the rate of heat transfer from the electric elements. Add air for a closer fit and increased insulation - release air for a freer fit and reduced insulation.

2. Inflating - The inflation/deflation tube is located under a zipper opening on the upper chest. Blowing into this tube inflates the insert. The more air in the insert, the better the vest will insulate and the closer it will 'hug' your body. When not adjusting the insert's air pressure, keep the inflation tube covered with the attached cap.

3. Deflating/Adjusting - Pressing a fingertip gently against the center of the one way valve located at the end of the inflation tube will reduce the insert air pressure.

4. Deflating for Packing and Storage - Inserting the inflation tube cap backwards (small end in) will keep the one way valve open allowing the vest to be packed compactly or stuffed into its self-store pocket. (illustration A)

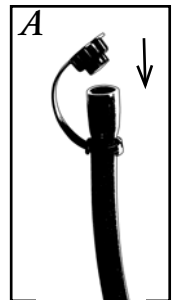

5. Custom Shortening the Inflation Tube - Remove the one way valve at the end of the inflation tube (it comes out without tools). Shorten the inflation tube with a knife or scissors and reinstall the one way valve. Custom shortening the inflation tube about 2" is typical. (illustration B)



6. Repairs/Leaks - In normal use the AirVantage™ insert will last the life of the garment. Over long periods it is normal for the vest to very slowly lose its internal pressure. Periodically adding small amounts of air is normal to maintain insulation. If the vest will not remain fully inflated over short intervals (minutes..), it should be repaired. Damaged garments should be returned for repairs to Aerostich galactic headquarters.

7. Long Term Storage - Do not store the vest for extended periods (months or years) tightly folded or compressed within its self-store pocket. For long periods of storage, either hang or fold loosely.

8. Laundry and Care - Hand wash with mild soap or detergent. Gently wring and then air dry.

9. Powercord Routing - Same as regular Kanetsu vests. For additional strain relief, clip the cord to the vest's hem as shown. (illustration C)

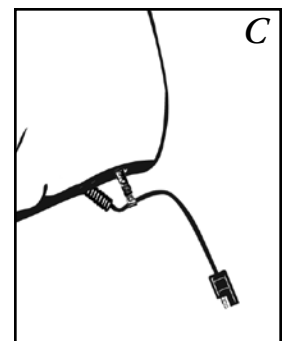

10. If you have any questions please contact us at 218 722 1927 or <products@aerostich.com>

11. Go ride your motorcycle.